



Facebook



WhatsApp



Twitter



LinkedIn



Instagram



YouTube



INFITEK

Laboratory and Medical equipment
one-stop solution provider

Infitek Co., Ltd.

TEL: +86-531-88982330
FAX: +86-531-88983691
Website: infitek.com
Email: info@infitek.com
Service: service@infitek.com
Address: Room 201A, Building 9 (Block B), No. 2679,
Hechuan Road, Minhang District, Shanghai,P.C.201100

Infitek Inc.

522w Riverside Ave Ste N, Spokane, wa 99201
Email: Info@infitek.com



WhatsApp



LinkedIn



YouTube

INFITEK CO., LTD.

PRODUCT BROCHURE

Colorimeter

SP-CLR410C SP-CLR411C SP-CLR412C

Features

With Auto calibration

Different apertures: Two Apertures / Small Aperture / Big Aperture

Supports both SCI and SCE test which is more consistent with result of visual method.

Many different kinds of test parameters: Opacity, whiteness index, yellowness index and other 30 kinds of test parameters

Provide 26 kinds of illuminants for choice

Good repeatability for stable measurement (Delta E*ab 0.08)

- Auto calibration
- Display Accuracy:0.01
- Different apertures: Two Apertures / Small Aperture / Big Aperture
- Test Aperture/Illuminated Area: Φ 8mm/ Φ 11mm; Φ 4mm/ Φ 6mm; Φ 8mm/ Φ 11mm, Φ 4mm/ Φ 6mm



Description

- It has auto calibration to make it simple in operation and contains 30 kinds of parameters and 26 kinds of illuminants. Two apertures version are with switchable apertures to measure samples with different sizes.

Specifications

Model	SP-CLR410C	SP-CLR411C	SP-CLR412C
Type	Economical (Big Aperture)	Economical (Small Aperture)	Economical (Two Apertures)
Color	Green		
Geometry	D/8 (Diffused illumination, 8°viewing) SCI (specular component included),SCE (specular component excluded)		
Repeatability	Chromaticity Value: Standard deviation $\Delta E^*ab \leq 0.04$ Average : $dE^*ab \leq 0.05$ Max.: $dE^*ab \leq 0.08$ (When a white tile is measured 30 times at 5 seconds interval)		
Inter-instrument Agreement	$\Delta E^*ab \leq 0.4$		
Display Accuracy	0.01		
Test Aperture/Illuminated Area	Φ 8mm/ Φ 11mm	Φ 4mm/ Φ 6mm	Φ 8mm/ Φ 11mm, Φ 4mm/ Φ 6mm
Color Space and Indices	Reflectance, CIE-Lab, CIE-LCh, Hunter Lab, CIE-Luv, XYZ, Yxy, RGB, Color Difference (ΔE^*ab , ΔE^*cmc , ΔE^*94 , ΔE^*00), Whiteness Index (ASTM E313-00, ASTM E313-73, CIE/ISO, AATCC, Hunter, Taube Berger Stensby), Yellowness Index(ASTM D1925, ASTM E313-00, ASTM E313-73), Blackness Index(My,dM), Staining Fastness, Color Fastness, Tint(ASTM E313-00), Color Density CMYK(A,T,E,M), Metamerism Index Milm, Munsell, Opacity, Color Strength		
Illuminants	A,B,C,D50,D55,D65,D75,F1,F2,F3,F4,F5,F6,F7,F8,F9,F10,F11,F12,CWF,U30,U35,DLF,NBF,TL83,TL84		
Support Color Matching Software	No		
Light Source	LED		
Camera	No		
Calibration	Auto		
Software	Windows		
Accuracy Guarantee	Pass National Metrology Level I		
Observer	2°, 10°		
Sphere Size	40mm		
Spectroscopic Method	Integrated optics		
Sensor	CMOS Sensor		
Wavelength interval	10nm		
Wavelength Range	400-700nm		
Reflectance Range	0-200%		
Reflectance Resolution	0.01%		
Reflectance Resolution	0.01%		
Measurement Time	About 1 second		
Display	IPS full color screen ,2.4 inches		
Battery	Rechargeable, 8,000 times continuous tests, 3.7V/3000mAh		
Light Source Lifetime	10 years, 1 million tests		
Language	English		
Storage	100 pieces of data		
Dimensions (L*W*H)	180*60*51mm		
Weight	280g		

Colorimeter

CLR-T

Note:

- Main difference of SP-CLR410C/SP-CLR411C/SP-CLR412C is the aperture size and quantity.
- Illuminated area is same as instrument aperture

Product structure

- Economical (Big Aperture/Small Aperture)

- Economical (Two Apertures)

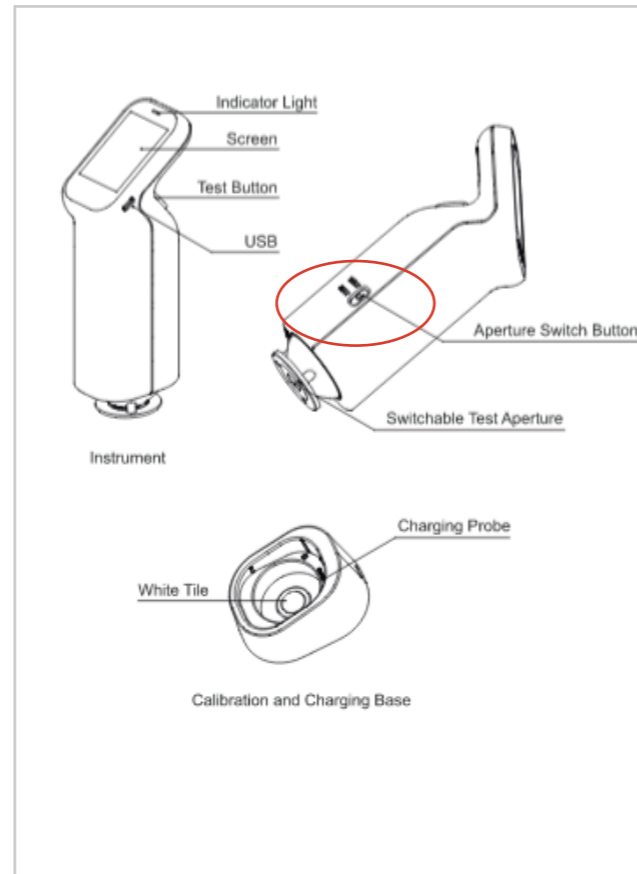
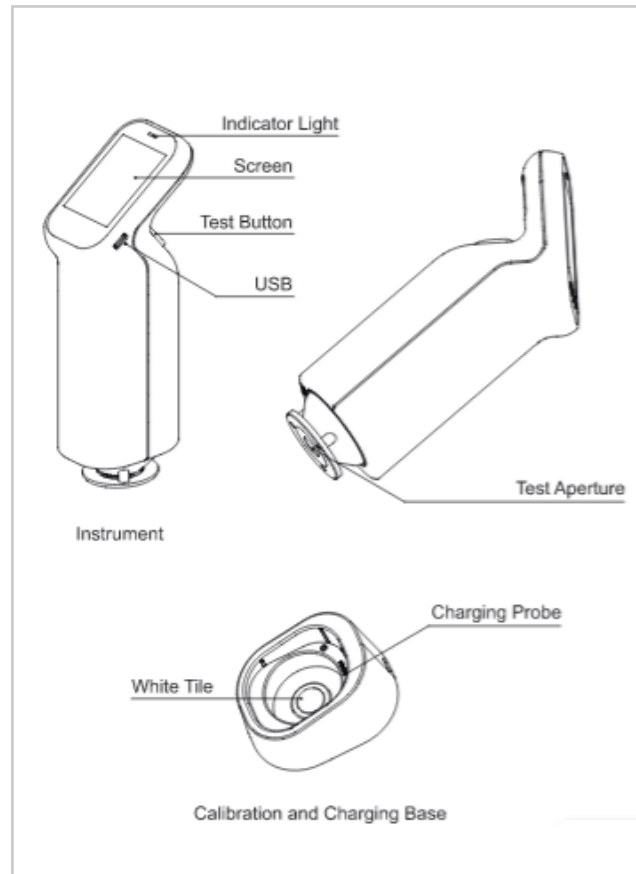

Features

- Visual measurement of color matching to determine material color;
- Design in conformity with internationally accepted color scale of Lovibond;
- Simple structure and easy to operate.

Specification

Model	CLR-T
Measurement range	Red R0.1-R79.9 Lovibond
	Yellow R0.1-R79.9 Lovibond
	Blue R0.1-R49.9 Lovibond
	Neutral 0.1-3.9 Lovibond
Minimum Reading	0.1 Lovibond
White board diffuse reflectance	>80%
Magnification	1.9X
	10mm 20mm 40mm
	25.4mm 20mm 40mm
Dimension of Colorimetric dishes	133.4mm 20mm 40mm
Weight (Gross)	11 kg
Overall dimension	620mm×440mm×300mm

Colorimeter

SP-CLR420C SP-CLR421C SP-CLR422C



Auto calibration



Display Accuracy:0.01



Portable and massive color card database



Different apertures: Two Apertures / Small Aperture / Big Aperture



Test Aperture/Illuminated Area: Φ 8mm/
 Φ 11mm; Φ 4mm/ Φ 6mm; Φ 8mm/ Φ 11mm,
 Φ 4mm/ Φ 6mm

Description

- It develops new color measurement method of colorimeter with build-in camera to see test area, UV light source for fluorescence color measurement; It can be connected to mobile APP and has unlimited storage memory; With built-in color card, you can find similar colors anytime, anywhere.

Features

- With Auto calibration
- Different apertures:
Two Apertures / Small Aperture / Big Aperture
- Supports both SCI and SCE test which is more consistent with result of visual method.
- Many different kinds of test parameters:
Opacity, whiteness index, yellowness index and other 30 kinds of test parameters
- Provide 26 kinds of illuminants for choice
- Good repeatability for stable measurement (Delta E*ab 0.06)
- Portable and massive color card database
 - 1)Connect to mobile phone APP to create database to upload the color shades from printing, paint, textile color cards.
 - 2)No need to carry big and heavy color card, we can find color card database from Colormeter Pro APP and find the closed/similar color easier and faster.
- Cloud database, more convenient to view and upload
 - 1)Official color card databases are available. Personal users can update color information to cloud and share between different instruments which make color management much easier.
 - 2)Enterprise users can create and manage their own color library and formula information in the cloud and share the information to their customers and suppliers through the unique invitation code.
- Better performance than traditional colorimeter
 - 1)UV for fluorescence material test
 - 2)Camera to see the test area to avoid test error
 - 3)Paint color matching software: user can use mobile phone App to achieve color correction function.

Specifications

Model	SP-CLR420C	SP-CLR421C	SP-CLR422C
Type	Spectral (Big Aperture)	Spectral (Small Aperture)	Spectral (Two Apertures)
Color	Blue		
Geometry	D/8(diffused illumination,8 degree viewing) SCI (specular component included),SCE (specular component excluded)		
Repeatability	Chromaticity Value: Standard deviation $\Delta E^*ab \leq 0.03$ Average : $dE^*ab \leq 0.04$ Max.: $dE^*ab \leq 0.06$ (When a white tile is measured 30 times at 5 seconds interval)		
Inter-instrument Agreement	$\Delta E^*ab \leq 0.4$		
Display Accuracy	0.01		
Test Aperture/Illuminated Area	$\Phi 8mm / \Phi 11mm$	$\Phi 4mm / \Phi 6mm$	$\Phi 8mm / \Phi 11mm, \Phi 4mm / \Phi 6mm$
Color Space and Indices	Reflectance, CIE-Lab, CIE-LCh, Hunter Lab, CIE-Luv, XYZ, Yxy, RGB, Color Difference ($\Delta E^*ab, \Delta E^*cmc, \Delta E^*94, \Delta E^*00$), Whiteness Index (ASTM E313-00, ASTM E313-73, CIE/ISO, AATCC, Hunter, Taube Berger Stensby), Yellowness Index(ASTM D1925, ASTM E313-00, ASTM E313-73), Blackness Index(My,dM), Staining Fastness, Color Fastness, Tint(ASTM E313-00), Color Density CMYK(A,T,E,M), Metamerism Index Milm, Munsell, Opacity, Color Strength		
Illuminants	A,B,C,D50,D55,D65,D75,F1,F2,F3,F4,F5,F6,F7,F8,F9,F10,F11,F12,CWF,U30,U35,DLF,NBF,T L83,TL84		
Light Source	LED+UV		
Camera	Yes		
Calibration	Auto		
Software	Android, IOS, Windows		
Accuracy Guarantee	Pass National Metrology Level I		
Observer	2°, 10°		
Sphere Size	40mm		
Spectroscopic Method	Integrated optics		
Sensor	CMOS Sensor		
Wavelength interval	10nm		
Wavelength Range	400-700nm		
Reflectance Range	0-200%		
Reflectance Resolution	0.01%		
Reflectance Resolution	About 1 second		
Measurement Time	USB, bluetooth		
Display	IPS full color screen ,2.4 inches		
Battery	Rechargeable, 8,000 times continuous tests, 3.7V/3000mAh		
Light Source Lifetime	10 years, 1 million tests		
Language	English		
Storage	APP Mass Storage		
Dimensions (L*W*H)	180*60*51mm		
Weight	280g		

Note:

- Main difference of SP-CLR420C/SP-CLR421C/SP-CLR422C is the aperture size and quantity
- Illuminated area is same as instrument aperture)

Product structure

• Spectral (Big Aperture/Small Aperture)

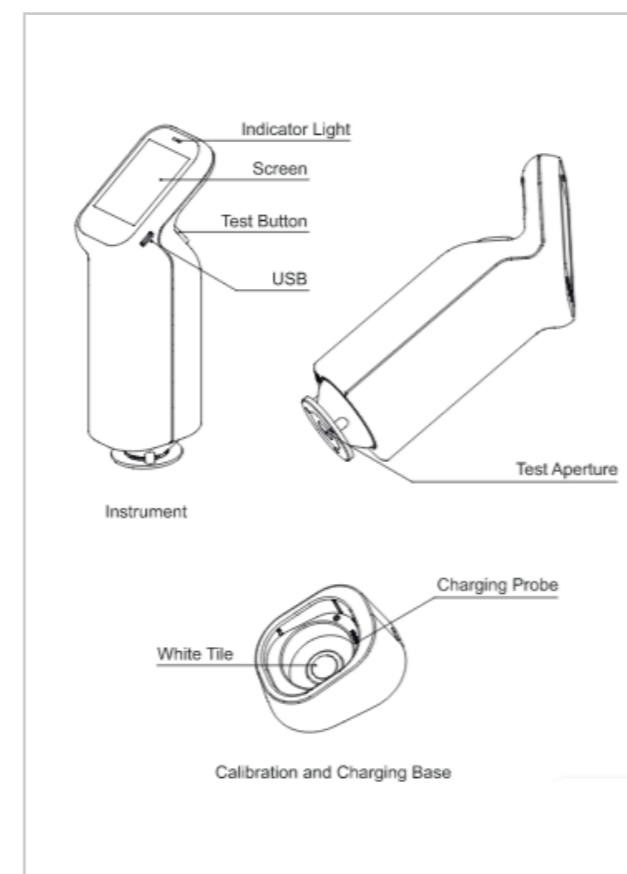

• Spectral (Two Apertures)



Colorimeter

SP-CLR10QC



Features

- High performance, but low price;
- Higher short-term repeatability accuracy: $OE < 0.03$;
- Light and cross dual positioning function;
- Equipped with rechargeable lithium ion battery, it has no need to repeatedly purchase batteries;
- $\Phi 4$ mm measuring caliber, portable structure, suitable for more measuring occasions;
- White mainstream shape, color box fast packaging, convenient transportation;
- Built-in white board parameters, no need for black and white board correction.
- No need to connect the computer, and it can be used immediately after starting up, making the measurement simpler!

Description

- SP-CLR10QC economical practical color difference instrument humanized interface design allows you to easily learn to operate the light and cross dual positioning work.

Specification

Model	SP-CLR10QC
Size	205 x67x80mm
Lighting mode	87D
Weight	approx. 400g (battery included)
Standards compliant	CIE No.15, GB/T 3978
Battery	Rechargeable lithium ion battery 3.7V@3200 mAh
Inductor	silicon photodiode
Lighting source	life span of 5 years is more than 1.6 million measurements
Measuring caliber	$\Phi 4$ mm
Display screen	TFT true color 2.8in @(16:9)
Color space	CIE lab
Interface	USB power supply only
Observer Angle	CIE 10° standard observer
Storage data	100 standard samples, 10000 samples
Observation source	D65
Operating temperature range	0-40°C(32-104 °F)
Display	chromaticity value, chromaticity value/graph, pass/fail results, color bias
Storage Temperature Range	-20~50°C(-4~122 F)
Measurement time	1.5 seconds
PC software	no software
Repeatability	OE* AB0.03 (average of 30 times)
Standard accessories	power adapter, manual, wristband, 4 platform measuring caliber
Difference between stations	AE* AB0.4 (average value of BCRA series 12 color plates)
Optional accessories	micro printer, powder test box

Colorimeter

SP-CLR60CP

Application Industry

SP-CLR60CP spectrophotometer is widely used in plastic, electronic, paint, ink, textile, garment, printing and dyeing, food, medical, cosmetic, industries, scientific research institutes, schools and laboratories. It can precisely measure kinds of color indexes in various color spaces and easy to use with powerful functions. The instrument is equipped with high-end color management software which can be connected to PC to achieve more extension functions.



Features

- Switchable 8mm and 4mm measuring apertures, easy to measure concave surface;
- Higher measurement stability and accuracy, $\Delta E^*ab < 0.03$;
- More color spaces, various color indexes, and extensive applicability;
- Double locating: illuminating locating and cross locating;
- Configured with high-capacity rechargeable Li-ion battery;
- Built-in white plate parameters and physical white calibration board, easy to operate;
- New integrating sphere optical path design, ensuring more stable measurement;
- Measurement data can pass national metrology authentication.

Specification

Model	SP-CLR60CP
Illuminating/Viewing Geometry	8°/ d
Light Source	LED Light
Sensor	silicon photodiode array
Measuring aperture	Φ8mm flat aperture; Φ4mm tip aperture
Color Space	CIE LAB, XYZ, LCh, CIE RGB, CIE LUV
Color Difference Formula	$\Delta E^*ab, \Delta E(h), \Delta E^*uv, \Delta E^*94, \Delta E^*cmc(2:1), \Delta E^*cmc(1:1), \Delta E^*00$
Other Chromaticity Data	WI (E313, CIE, AATCC, Hunter), YI (D1925, 313), Color Fastness, Staining Fastness, J PC79, BFD (1.5:1), FMCI I
Observer	CIE 10°
Illuminant	D65, A, C, D50, F2, F6, F7, F8, F10, F11, F12
Display Data	Colorimetric Value, Color Difference Value/Graph, PASS/-FAIL Result, Color Offset
Measuring Time	0.4s
Repeatability	$\Delta E^*ab < 0.03$ (Average of 30 measurements of standard white plate within 5s)
Errors between each instrument	within $\Delta E^*ab < 0.2$
Dimension	205*67*80mm
Weight	500g
Battery	rechargeable lithium-ion battery 3.7V @ 3200mAh
Lamp Life	5 years, more than 1.6 million measurements
Screen	TFT 2.8 inch (16)
Interface	USB/ RS-232
Storage	100 Standards, 20000 Samples
Operating Temperature	0~40°C (32~104°F)
Storage temperature	-20~50°C (-4~122°F)
PC software	CQCS3 software
Optional accessory	miniature thermal printer, powder test box

Colorimeter

SP-CLR110



Features

- Built-in white plate parameters. No need to calibrate each time which realizes rapid measurement.
- Double Locating: Illuminating locating and precise cross locating.
- Switchable Double Measurement End Face: Large stable end face and small concave-convex end face.
- New Integrating Sphere Optical Path Design: Eliminating the stray light of main optical path and auxiliary optical path. Possessing the highest measurement stability and precision.
- 4mm Measuring Aperture.
- Equipped with rechargeable high-capacity Li-ion battery. No need to purchase battery repeatedly.
- Configures CQCS3 software. Connects PC computer to realize more functions.
- Having got SCM Metrological Certification, CE Certification, and ISO9001 Quality Management System Certification.
- Hand-head structure: small and convenient; makes the measurement easier.
- Exquisite appearance: adopts traditional and fashionable aesthetic designs.
- Spending huge sums on high-end mold. Product consistency approaches 100%.
- High cost performance: large output, good quality, cheap products.



Illuminating Locating, Cross Locating, Large Stable End Face, Small Concave-Convex End Face.

Specification

Model	SP-CLR110
Illuminating/Viewing Geometry	8/d
Measuring Aperture	Φ4mm
Detector	Silicon photoelectric diode
Locating	Illuminating Locating/Cross Locating
Measurement End Face	Large stable end-face and small concave-convex end-face
Color Space	CIE L*a*b*C*h* CIE L*a*b* CIE XYZ
Color Difference Formula	ΔE^*ab $\Delta L^*a^*b^*$ $\Delta E^*C^*h^*$
Light Source	D65
Light Source Device	LED blue light excitation
Errors Between Each Equipment	$\leq 0.80\Delta E^*ab$
Storage	100pcs standards 20000pcs samples
Repeatability	Standard deviation within ΔE^*ab 0.08 Average of 30 measurements of standard white plate
Language	English/Chinese
Weight	450g
Dimension	205×67×80 mm
Power source	Rechargeable lithium-ion battery 3.7V@3200mAh
Lamp Life	5 years, more than 1.6 million measurements
Charging Time	8 hours--100% electricity
PC Software	CQCS3 Software
Printer (optional)	Miniature thermal printer

Colorimeter

SP-CLR145



Features

- Built-in white plate parameters. No need to calibrate each time which can perform measurement quickly.
- Double Locating: Illuminating locating and precise cross locating.
- Switchable Double Measurement End Face: Large stable end face and small concave-convex end face.
- New 45°/0° Optical Path Design: Significantly improves the measurement stability and precision.
- 8mm Measuring Aperture.
- Equipped with rechargeable high-capacity Li-ion battery. No need to purchase battery repeatedly.
- Configure CQCS3 software. Connects PC computer to realize more functions.
- Having got SCM Metrological Certification, CE Certification, and ISO9001 Quality Management System Certification.
- Hand-head structure: small and convenient; makes the measurement easier.
- Exquisite appearance: adopts traditional and fashionable aesthetic designs.

Specification

Model	SP-CLR145
Illuminating/Viewing Geometry	45°/0°
Measuring Aperture	Φ8mm
Measurement End-face	Large stable end face and small concave-convex end face
Detector	Silicon photoelectric diode
Locating	Illuminating Locating/Cross Locating
Color Space	CIEL*a*b*C*h* CIEL*a*b* CIEXYZ
Color Difference Formula	ΔE^*ab $\Delta L^*a^*b^*$ $\Delta E^*C^*h^*$
Light Source	D65
Light Source Device	LED blue light excitation
Errors Between Each Equipment	$\leq 0.80\Delta E^*ab$
Storage	100pcs standards 20000pcs samples
Repeatability	Standard deviation within ΔE^*ab 0.08 Average of 30 measurements of standard white plate
Weight	500g
Dimension	205×67×80 mm
Power source	Rechargeable lithium-ion battery 3.7V@3200mAh
Lamp Life	5 years, more than 1.6 million measurements
Charging Time	The first charging time is 8 hours--100% electricity
PC Software	CQCS3 Software
Printer (optional)	Miniature thermal printer

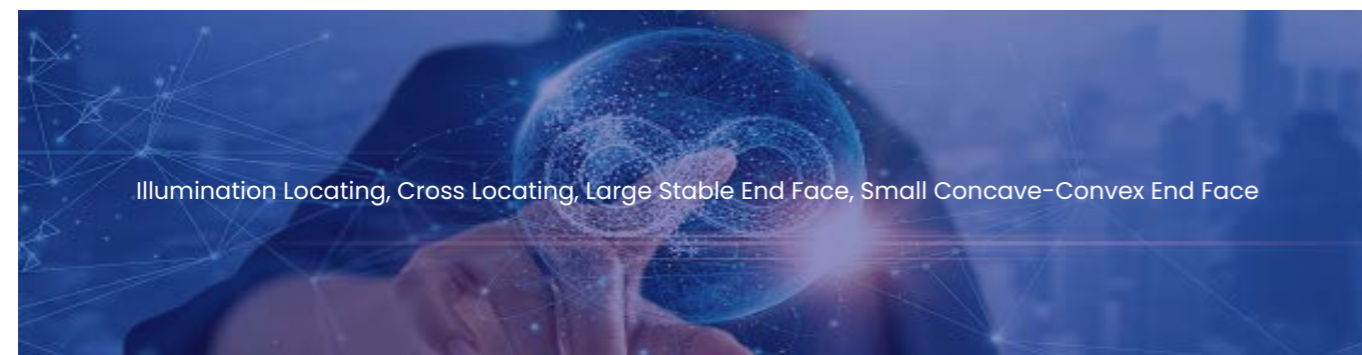

Illumination Locating, Cross Locating, Large Stable End Face, Small Concave-Convex End Face

Colorimeter

SP-CLR200



Features

● Leading Humanity Design and Convenient Operation

- One-touch access to measurement interface
- Structure design in line with ergonomics
- East-to-use operating interface

● Convenient and Fast Locating

Illumination locating is a fast, simple and convenient locating which is created by us.

● Advanced Power Management Design

3nh is the first enterprise using high capacity Li-ion battery in colorimeter.

3nh Li-ion battery can be repeatedly charged which will save cost. Meanwhile, it can measure more than 3000 times on one charge to ensure the stability of long time measurement.

● Stable Measurement Performance

- The repeatability ΔE is 0.08.
- Portable structure design which is more conducive to keeping the instrument stable when using.

● PC Software—Realizes More Function Expansion

Be able to perform color difference analysis, color difference cumulative analysis, chromaticity index, color sample database management, simulating object color, etc.

Specification

Model	SP-CLR200
Illuminating/Viewing Geometry	8/d
Measuring Aperture	Φ8mm
Detector	Silicon photoelectric diode
Color Space	CIEL*a*b*C*h* CIEL*a*b*, CIEXYZ
Color Difference Formula	ΔE^*ab ΔL^*a^*b ΔE^*C^*h
Light Source	D65
Light Source Device	LED blue light excitation
Errors Between Each Equipment	$\leq 0.50\Delta E^*ab$
Storage	100pcs standards 20000pcs samples
Repeatability	Standard deviation within ΔE^*ab 0.08 Average of 30 measurements of standard white plate
Weight	500g
Dimension	205×70×100 mm
Power source	Rechargeable lithium-ion battery 3.7V@3200mAh
Lamp Life	3 years, more than 1 million measurements
Charging Time	2 hours (First time 8 hours--100% electricity)
Measurement Times Before Recharging	More than 3000 times
Operating Temperature/Humidity Range	-10~40 C, relative humidity 0~85% with no condensation
Data Interface	USB
Optional Accessory	Miniature thermal printer, Powder Test Box
Package Dimension (W*D*H)(mm)	360*170*310mm
G.W.(kg)	2.3kg

Colorimeter

SP-CLR300 SP-CLR310

Features

● Leading Humanity Design and Convenient Operation

Auto White and Black Calibration at Startup
Structure Design in line with Ergonomics
Easy-to-use Operation Interface



● Stable Measurement Performance

The average fluctuation of ΔE is less than 0.06, actually more in 0.03~0.06.
Portable structure design which is more conducive to keeping the instrument stable when using.

● Flexible and Accurate Locating

Camera locating can solve the problem of locating a small area. The minimum width of locating is 4mm.
Illumination locating is a fast, simple and convenient locating function which is the original function.

● More Measurement Modes

Three measuring apertures for more circumstances.
Five color spaces for more color schemes selection.
Three light sources for more circumstances.

● PC Software—Realizes More Function Expansion

The corresponding software serial number and password protection are configured.
Be able to perform color difference analysis, color difference cumulative analysis, chromaticity index, color sample database management, simulating object color, etc..

● National Patent and Innovative Technology

No.1 Camera locating and illumination location (NH310 has new functions of double locating.)
No. 2 Built-in white plate; Automatic calibration at startup (for SP-CLR310)
No. 3 Extended aperture (optional), available for measuring concave surface



Camera Locating
Illumination Locating



Built-in White Plate
Automatic Calibration at Startup



Extended Aperture(Optional)
Available for measuring concave surface



Configuring 8mm & 4mm apertures

Specification

NH Series Colorimeter Specifications		
	SP-CLR300	SP-CLR310
Illuminating/Viewing Geometry	8/d	8/d
Measuring Aperture	Φ8mm	Φ8mm/Φ4mm
Detector	Silicon photoelectric diode	Silicon photoelectric diode
Color Space	CIEL*a*b*C*h* CIEL*a*b*	CIEL*a*b*C*h* CIEL*a*b* CIEXYZ CIERGB CIEL*u*v* CIEL*C*h* Yellowness & Whiteness Color Fastness
Color Difference Formula	ΔE^*ab ΔL^*a^*b ΔE^*C^*h	ΔE^*ab ΔL^*a^*b ΔE^*C^*h $\Delta ECIE94$ ΔE_{hunter}
Light Source	D65	D65 D50 A
Light Source Device	LED blue light excitation	LED blue light excitation
Errors Between Each Equipment	$\leq 0.40\Delta E^*ab$	$\leq 0.40\Delta E^*ab$
Storage	100pcs standards 20000pcs samples	100pcs standards 20000pcs samples
Repeatability	Standard deviation within ΔE^*ab 0.07	Standard deviation within ΔE^*ab 0.06
	Average of 30 measurements of standard white plate	Average of 30 measurements of standard white plate
Weight	500g	500g
Dimension	205×70×100 mm	205×70×100 mm
Power source	Rechargeable lithium-ion battery 3.7V@3200mAh	Rechargeable lithium-ion battery 3.7V@3200mAh
Lamp Life	5 years, more than 1.6 million measurements	5 years, more than 1.6 million measurements
Charging Time	2 hours (first time 8 hours--100% electricity)	2 hours (first time 8 hours--100% electricity)
Measuring Times Before Recharging	more than 3000 times	more than 3000 times
Operating Temperature/Humidity Range	-10~40 ℃, relative humidity 0~85% with no condensation	-10~40 ℃, relative humidity 0~85% with no condensation
Data Interface	USB	USB
Extended Aperture (optional)	-	Φ8mm extended aperture, available for measuring concave surface
Printer (optional)	Miniature thermal printer	Miniature thermal printer

Colorimeter

SP-CLR701



Application

- With 8mm aperture, SP-CLR701 spectrophotometer is widely suitable for the industry production and quality inspection of accurate color difference control like plastic electronics, paint and ink, textile printing and dyeing, printing, ceramic industry, etc.

Technical Advantages

- Ergonomic design and simple-to-operate measuring device

SP-CLR701 spectrophotometer has a beautiful, smooth shape and comfortable grip, which is in line with the structure design of human mechanics, and also fits the palm for continuous testing, so that you can use it quickly and easily. An automatic measuring device is added, which is portable, quick and easy to measure.

- Adopts full waveband balanced LED light source

The full waveband balanced LED light source ensures sufficient spectral distribution in the visible light range, so as to avoid the spectral loss of white LED in specific waveband, and ensure the measurement speed and accuracy of the measurement results.

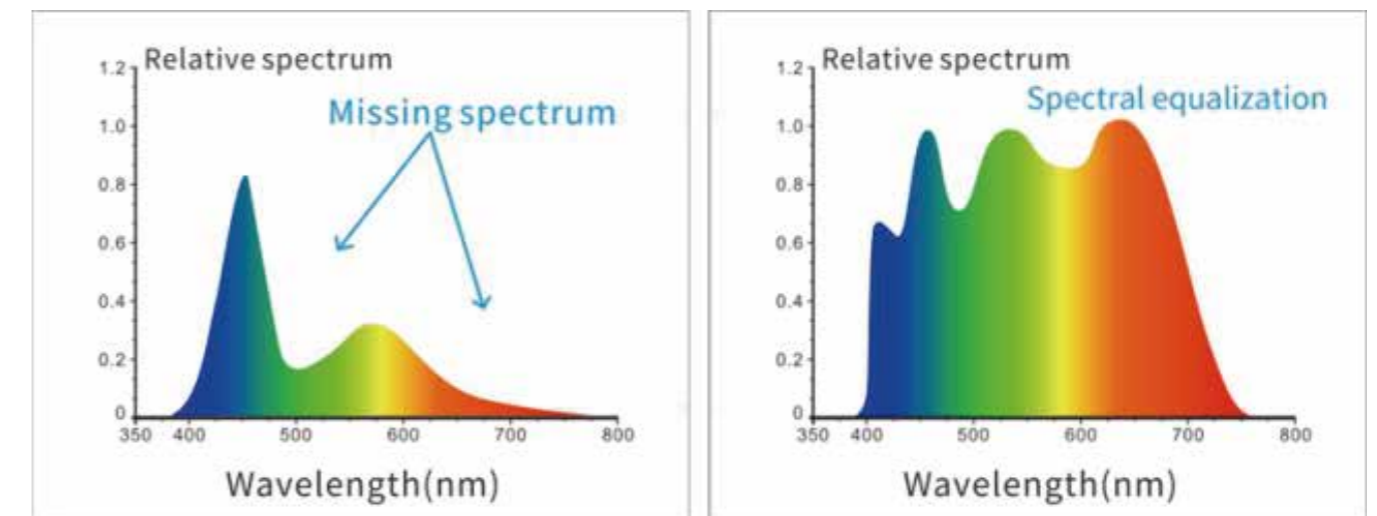

- Silicon photodiode array sensor (24 groups with double rows)

The dual-24 array sensor with larger area has strong light but not saturate, higher sensitivity of low light and wider spectral response range, which ensures the measurement speed, accuracy, stability and consistency of the instrument.

- Calibration Certificate

Each SP-CLR701 spectrophotometer has been verified and tested. After leaving the factory, each instrument is verified according to the measurement standards of authoritative verification departments, and the measurement data are traceable to the National Metrological Institute to ensure the authority of the instrument test data.

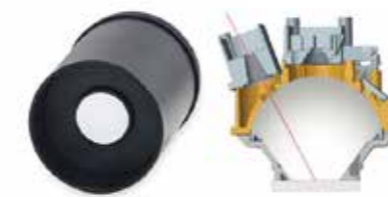

- ETC real-time calibration technology

SP-CLR701 spectrophotometer adopts imported standard white board, which is resistant to yellowing and dirt infiltration and can be wiped, ensuring the long-term accuracy of the instrument. An innovative ETC real-time Calibration technique is also used, with a built-in standard white board in the optical system, which is reliably accurate and repeatable for each Test.

Specification

Model	SP-CLR701
Optical Geometry	D/8(diffused illumination, 8-degree viewing angle) SCI Mode Comply to CIE No.15, GB/T 3978,GB 2893,GB/T 18833,I-SO7724-1,ASTM E1164,DIN5033 Teil7
Characteristic	Φ8mm apertures, which is used for accurate color measurement and quality control in plastic electronics, paint and ink, textile and garment printing and dyeing, printing, ceramics and other industries
Integrating Sphere Size	Φ40mm
Light Source	Combined full spectrum LED light source
Spectrophotometric Mode	Flat Grating
Sensor	Silicon photodiode array (double row 24 groups)
Wavelength Range	400~700nm
Wavelength Interval	/
Semiband Width	10nm
Measured Reflectance Range	L:0~100; reflectivity:The reflectivity can be measured at 1 specific wavelength specified by the user (default: 550nm)
Measured Aperture	Φ8mm
Specular Component	SCI
Color Space	CIE LAB,XYZ,Yxy,LCh
Color Difference Formula	$\Delta E^*ab, \Delta E^*00$
Other Colorimetric Index	/
Observer Angle	10°
Illuminant	D65,A,F2(CWF)
Displayed Data	Reflectivity (the user specifies the reflectivity at 1 specific wavelength), Samples Chromaticity Values, Color Difference Values/Graph, PASS/FAIL Result, Color Simulation, Color Offset

Specification

Model	SP-CLR701
Displayed Accuracy	0.1
Measurement Time	About 1.5s
Repeatability	Chromaticity value: MAV/SCI, within ΔE^*ab 0.1 (When a white calibration plate is measured 30 times at 5 second intervals after white calibration)
Inter-instrument Error	MAV/SCI, Within ΔE^*ab 0.4 (Average for 12 BCRA Series II color tiles)
Measurement Mode	Single Measurement, Average Measurement(2~99times)
Locating Method	Stabilizer cross position
Dimension	L*W*H=81X71X214mm
Weight	About 460g
Battery	Li-ion battery, 6000 measurements within 8 hours
Illuminant Life Span	5 years, more than 3 million times measurements
Display	3.5-inch TFT color LCD, Capacitive Touch Screen
Data Port	USB
Data Storage	Standard 500 Pcs, Sample 10000 Pcs
Language	Simplified Chinese, English, Traditional Chinese
Operating Environment	0~40℃, 0~85%RH (no condensing), Altitude < 2000m
Storage Environment	-20~50℃, 0~85%RH (no condensing)
Standard Accessory	Power Adapter, USB Cable, User Guide, White and Black Calibration Cavity, Protective Cover, Wrist strap, 8mm flat aperture
Optional Accessory	USB Micro Printer, Powder Test Box
Notes	Technical parameters are only for reference, subject to the actual sale of the product

Colorimeter

SP-CLR702



Application

- With 8mm aperture, SP-CLR702 spectrophotometer is widely suitable for the industry production and quality inspection of accurate color difference control like plastic electronics, paint and ink, textile printing and dyeing, printing, ceramic industry, etc.

Technical Advantages

● Adopt full waveband balanced LED light source

The full waveband balanced LED light source ensures sufficient spectral distribution in the visible light range, so as to avoid the spectral loss of white LED in specific waveband, and ensure the measurement speed and accuracy of the measurement results.

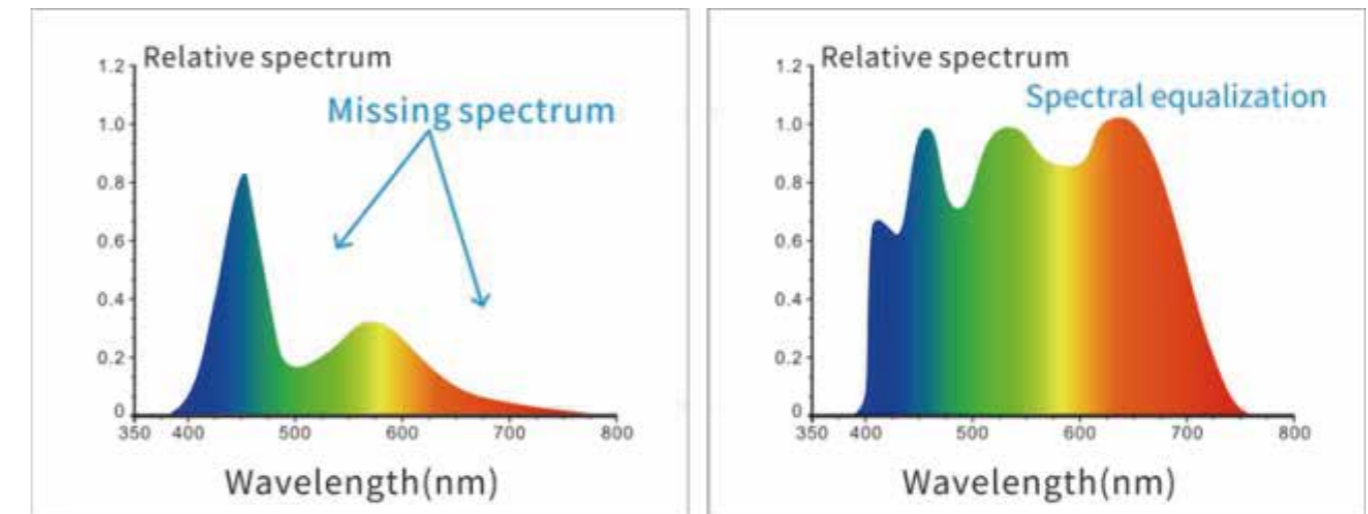

● Silicon photodiode array sensor (24groups with double rows)

The dual-24 array sensor with larger area has strong light but not saturate, higher sensitivity of low light and wider spectral response range, which ensures the measurement speed, accuracy, stability and consistency of the instrument.

● Ergonomic design and easy measuring device

SP-CLR702 spectrophotometer has a beautiful, smooth shape and comfortable grip, which is in line with the structure design of human mechanics, and fits the palm for continuous testing, so that you can use it quickly and easily. An automatic measuring device is added, which is portable, quick and easy to measure.

● Calibration Certificate

Each SP-CLR702 spectrophotometer has been verified and tested. After leaving the factory, each instrument is verified according to the measurement standards of authoritative verification departments, and the measurement data are traceable to the National Metrological Institute to ensure the authority of the instrument test data.

● ETC real-time calibration technology

SP-CLR702 spectrophotometer adopts imported standard white board, which is resistant to yellowing and dirt infiltration and can be wiped, ensuring the long-term accuracy of the instrument. An innovative ETC real-time Calibration technique is also used, with a built-in standard white board in the optical system, which is reliably accurate and repeatable for each Test.

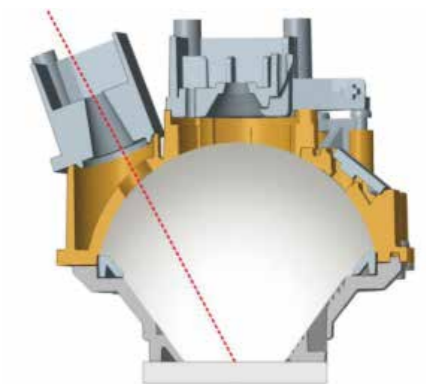

- Color management software

SQCX quality management software with SP-CLR702 spectrophotometer is suitable for quality monitoring and color data management in various industries. It will analyze the user's color management data, compare color differences, generate test reports, provide multiple color space measurement data, and customize the customer's color management.

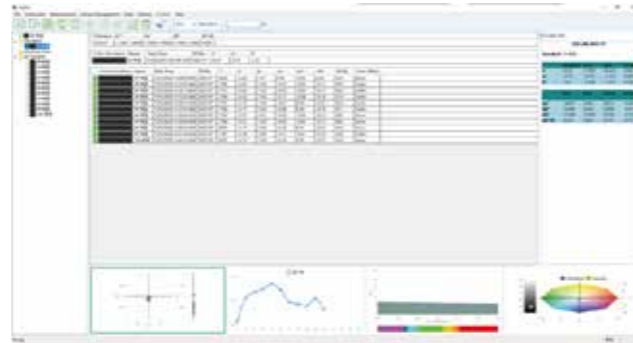

Specification

Model	SP-CLR702
Optical Geometry	D/8(diffused illumination, 8-degree viewing angle) SCI Mode
Characteristic	With $\Phi 8\text{mm}$ apertures, it is used for accurate color measurement and quality control in plastic electronics, paint and ink, textile and garment printing and dyeing, printing, ceramics and other industries
Integrating Sphere Size	$\Phi 40\text{mm}$
Light Source	Combined full spectrum LED light source
Spectrophotometric Mode	Flat Grating
Sensor	Silicon photodiode array (double row 24 groups)
Wavelength Range	400~700nm
Wavelength Interval	/
Semiband Width	10nm
Measured Reflectance Range	L:0~100; reflectivity: The reflectivity can be measured at 3 specific wavelengths specified by the user (default: 440nm, 550nm, 600nm)
Measured Aperture	$\Phi 8\text{mm}$
Specular Component	SCI
Color Space	CIE LAB, XYZ, Yxy, LCh
Color Difference Formula	$\Delta E^*ab, \Delta E^*00$
Other Colorimetric Index	/
Observer Angle	10°
Illuminant	D65, A, F2(CWF)
Displayed Data	Reflectivity (the user specifies the reflectivity at 3 specific wavelengths), Samples Chromaticity Values, Color Difference Values/Graph, PASS/FAIL Result, Color Simulation, Color Offset

Specification

Model	SP-CLR702
Displayed Accuracy	Display 0.1, storage 0.01
Measuring Time	About 1.5s
Repeatability	Chromaticity value: MAV/SCI, within ΔE^*ab 0.08 (When a white calibration plate is measured 30 times at 5 second intervals after white calibration)
Inter-instrument Error	MAV/SCI, Within ΔE^*ab 0.4 (Average for 12 BCRA Series II color tiles)
Measurement Mode	Single Measurement, Average Measurement(2~99times)
Locating Method	Stabilizer cross position
Dimension	L*W*H=81X71X214mm
Weight	About 460g
Battery	Li-ion battery, 6000 measurements within 8 hours
Illuminant Life Span	5 years, more than 3 million times measurements
Display	3.5-inch TFT color LCD, Capacitive Touch Screen
Data Port	USB
Data Storage	Standard 500 Pcs, Sample 10000 Pcs
Language	Simplified Chinese, English, Traditional Chinese
Operating Environment	0~40 C, 0~85%RH (no condensing), Altitude < 2000m
Storage Environment	-20~50 C, 0~85%RH (no condensing)
Standard Accessory	Power Adapter, USB Cable, User Guide, PC Software(Download from office website), White and Black Calibration Cavity, Protective Cover, Wrist strap, 8mm flat aperture
Optional Accessory	USB Micro Printer, Powder Test Box
Notes	Technical parameters are only for reference, subject to the actual sale of the product

Colorimeter

SP-CLR703



Application

- With 8mm flat and tip apertures, SP-CLR703 spectrophotometer is widely suitable for the industry production and quality inspection of accurate color difference control like plastic electronics, paint and ink, textile printing and dyeing, printing, ceramic industry etc.

Technical Advantages

- Adopts full waveband balanced LED light source

The full waveband balanced LED light source ensures sufficient spectral distribution in the visible light range, so as to avoid the spectral loss of white LED in specific waveband, and ensure the measurement speed and accuracy of the measurement results.

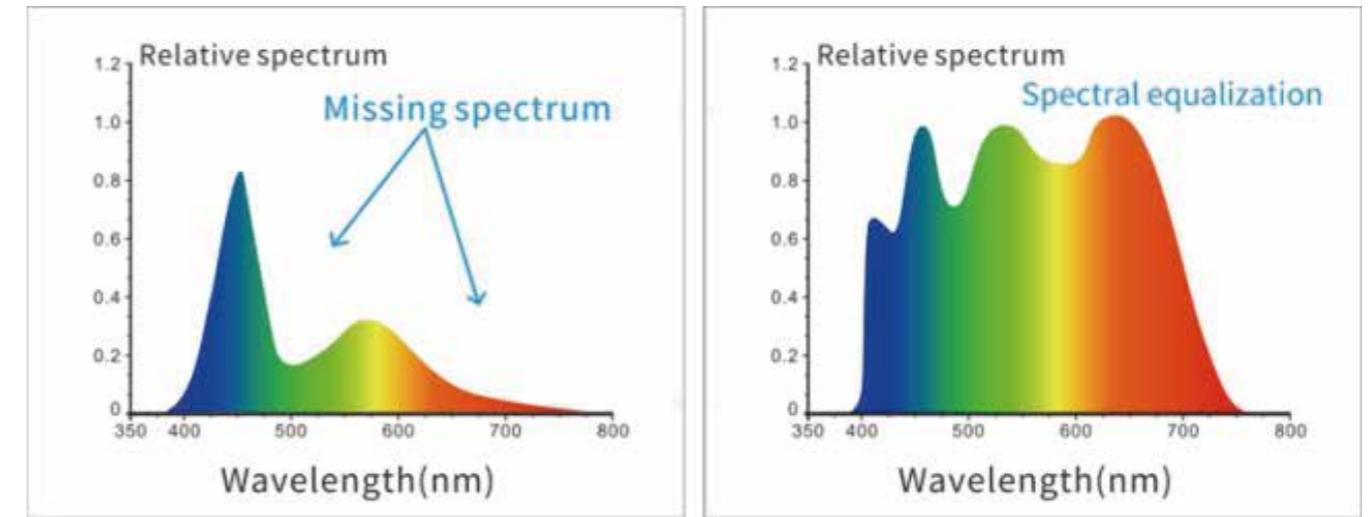

- International common use d/8 SCI/SCE Synthesis technology is adopted

SP-CLR703 spectrophotometer adopts D/8(diffused illumination, 8-degree viewing angle) which is widely applicable in the world, and SCI/SCE (specular component included/specular component excluded) Synthesis technology. It is suitable for color management and quality control in various industries such as color matching and coating, textile, plastic, food, building materials, cosmetics, etc.

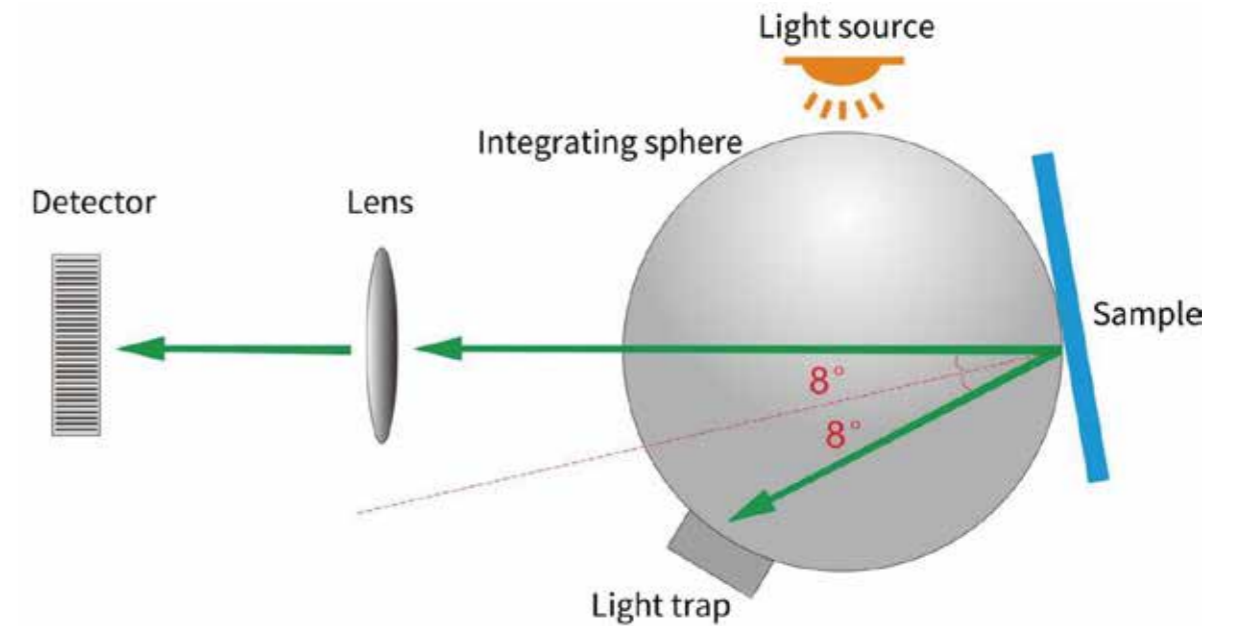

Technical Advantages

- Ergonomic design and easy measuring device

SP-CLR703 spectrophotometer has a beautiful, smooth shape and comfortable grip, which is in line with the structure design of human mechanics, and fits the palm for continuous testing, so that you can use it quickly and easily. An automatic measuring device is added, which is portable, quick and easy to measure.

- Silicon photodiode array sensor (32 groups with double rows)

The dual-32 array sensor with larger area has strong light but not saturate, higher sensitivity of low light and wider spectral response range, which ensures the measurement speed, accuracy, stability and consistency of the instrument.

- Calibration Certificate

Each SP-CLR703 spectrophotometer has been verified and tested. After leaving the factory, each instrument is verified according to the measurement standards of authoritative verification departments, and the measurement data are traceable to the National Metrotechnical Institute to ensure the authority of the instrument test data.

- ETC real-time calibration technology

SP-CLR703 spectrophotometer adopts imported standard white board, which is resistant to yellowing and dirt infiltration and can be wiped, ensuring the long-term accuracy of the instrument. An innovative ETC real-time Calibration technique is also used, with a built-in standard white board into the optical system, which is reliably accurate and repeatable for each Test.

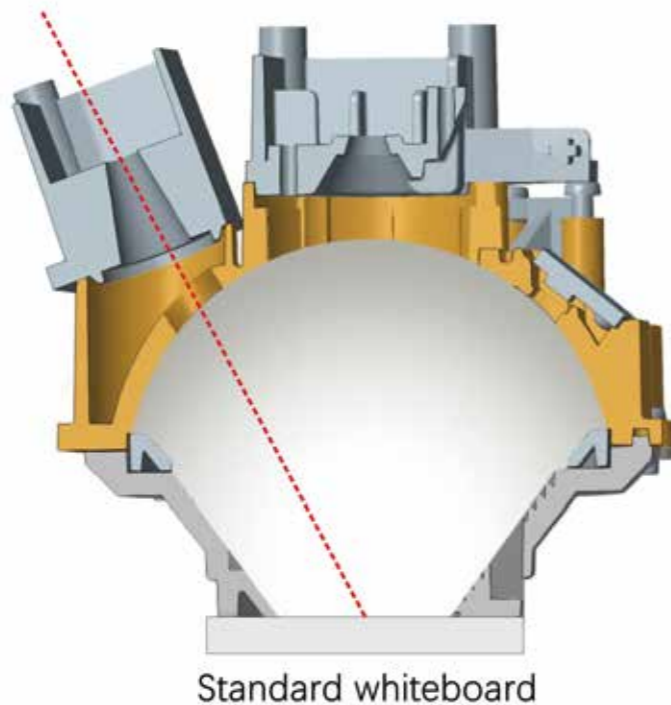

- Camera locating can clearly observe the measured area

SP-CLR703 spectrophotometer has a built-in camera for positioning, which can accurately determine whether the measured part of the object is the center of the target through real-time viewing by the camera, thus improving the measurement efficiency and accuracy.

- Color management software

SQCX quality management software with SP-CLR703 spectrophotometer is suitable for quality monitoring and color data management in various industries. Data the user's color management, compare color differences, generate test reports, provide multiple color space measurement data, and customize the customer's color management.

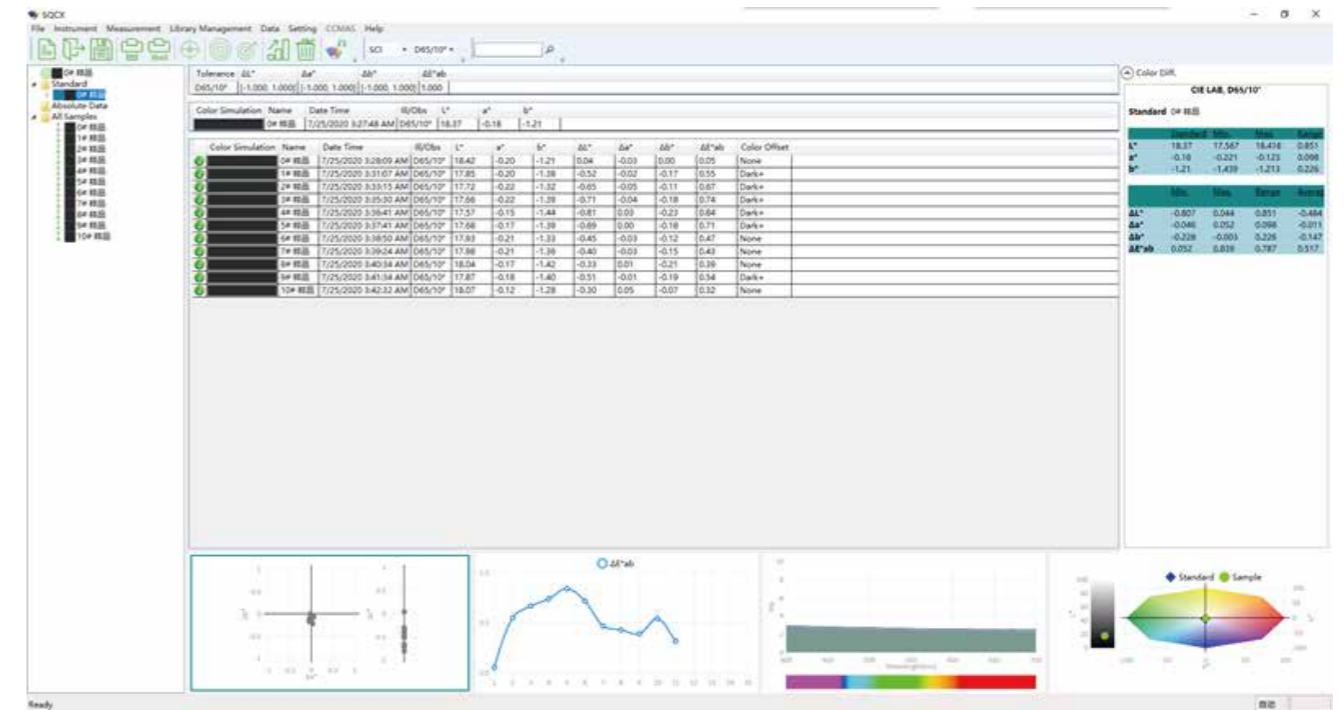

Specification

Model	SP-CLR703
Optical Geometry	D/8(diffused illumination, 8-degree viewing angle) SCI/SCE Mode Comply to CIE No.15, GB/T 3978,GB 2893,GB/T 18833,I-SO7724-1,ASTM E1164,DIN5033 Teil7
Characteristic	single apertures, more adaptability; Used for accurate color measurement and quality control in plastic electronics, paint and ink, textile and garment printing and dyeing, printing, ceramics and other industries
Integrating Sphere Size	Φ40mm
Light Source	Combined full spectrum LED light source, UV light source
Spectrophotometric Mode	Flat Grating
Sensor	Silicon photodiode array (double row 32 groups)
Wavelength Range	400~700nm
Wavelength Interval	10nm
Semiband Width	10nm
Measured Reflectance Range	L:0~120; reflectivity:0~200%
Measured Aperture	Single Apertures: Φ8mm/Φ10mm
Specular Component	SCI/SCE
Color Space	CIE LAB,XYZ,Yxy,LCh,s-RGB,βxy,Munsell(C/2)
Color Difference Formula	$\Delta E^*ab, \Delta E^*94, \Delta E^*cmc(2:1), \Delta E^*cmc(1:1), \Delta E^*00, \text{DIN}\Delta E99$
Other Colorimetric Index	WI(ASTM E313,CIE/ISO,AATCC,Hunter), YI(ASTM D1925,ASTM 313), Metamerism Index MI, Staining Fastness, Color Fastness, Color Strength, Opacity,Color Card Search
Observer Angle	2°/10°
Illuminant	D65,A,C,D50,F2(CWF),F7(DLF),F10(T-PL5),F11(TL84),F12(TL83/U30)
Displayed Data	Spectrogram/Values, Samples Chromaticity Values, Color Difference Values/Graph, PASS/FAIL Result, Color Simulation, Color Offset

Specification

Model	SP-CLR703
Displayed Accuracy	0.01
Measurement Time	About 1.5s (Measure SCI & SCE about 3.2s)
Repeatability	Chromaticity value: MAV/SCI, within ΔE^*ab 0.06 (When a white calibration plate is measured 30 times at 5 second intervals after white calibration)
Inter-instrument Error	MAV/SCI, Within ΔE^*ab 0.3 (Average for 12 BCRA Series II color tiles)
Measurement Mode	Single Measurement, Average Measurement(2~99times)
Locating Method	Camera Locating,stabilizer cross position
Dimension	L*W*H=81X71X214mm
Weight	About 460g
Battery	Li-ion battery, 6000 measurements within 8 hours
Illuminant Life Span	5 years, more than 3 million times measurements
Display	3.5-inch TFT color LCD, Capacitive Touch Screen
Data Port	USB
Data Storage	Standard 1000 Pcs, Sample 20000 Pcs(One data is able to include SCI/SCE)
Language	Simplified Chinese, English, Traditional Chinese
Operating Environment	0~40 C, 0~85%RH (no condensing), Altitude < 2000m
Storage Environment	-20~50 C, 0~85%RH (no condensing)
Standard Accessory	Power Adapter, USB Cable, User Guide, PC Software(Download from office website), White and Black Calibration Cavity, Protective Cover, Wrist strap, 8mm flat aperture, 8mm tip aperture
Optional Accessory	USB Micro Printer, Powder Test Box
Notes	Technical parameters are only for reference, subject to the actual sale of the product

Colorimeter

SP-CLR760



Features

- D / 8° geometric optical structure, conforming to CIE No.15, GB / T 3978, GB 2893, GB / T 18833, iso7724 / 1, ASTM e1164, din5033 teil7;
- Adopts combined LED light source with high life and low power consumption;
- Customized one 8mm or 4mm aperture (the flat/ tip measuring aperture can be switched easily, which is suitable for more tested sample)
- Dual optical path system, the optical resolution in the visible range is less than 10nm, which can measure the SCI and SCE spectrum of the sample at the same time;
- Accurate spectrum and lab data, used for color matching and accurate color transmission;
- High hardware configuration: 3.5-inch TFT true color screen, capacitive touch screen, 1000 line blazed grating, silicon photocell array detector with large photosensitive area, etc;
- USB interface, convenient for expansion of various functions;
- Super dirt resistant and stable standard white calibration board;
- Large capacity storage space, which can store more than 20000 pieces of test data
- 2/10 standard observer's angle, multiple light source modes, multiple surface color systems, can meet various standards of chromaticity indicators, and the needs of various customers for color measurement;
- Camera locating position and Stabilizer cross measurement position;
- PC software has powerful function expansion;

Specification

Model	SP-CLR760
Optical Geometry	Reflect: di:8°, de:8°(diffused illumination, 8-degree viewing angle); SCI (specular component included)/SCE (specular component excluded) ,excluded UV light source; Conforms to CIE No.15,GB/T 3978,GB 2893,GB/T 18833,ISO7724-1,ASTM E1164,DIN5033 Teil7;
Characteristic	Customized one aperture, It is used for precise color measurement and quality control in plastic electronics, paint and ink, textile and garment printing and dyeing, printing, ceramics and other industries, and for fluorescent sample measurement.

Specification

Model	SP-CLR760
Integrating Sphere Size	Φ40mm
Light Source	Combined full spectrum LED light source
Spectrophotometric Mode	Flat Grating
Sensor	Silicon photodiode array (double row 40 groups)
Wavelength Range	400~700nm
Wavelength Interval	10nm
Semiband Width	10nm
Measured Reflectance Range	0-200%
Measured Aperture	Customized one aperture: MAV:Φ8mm/Φ10mm; SAV:Φ4mm/Φ5mm
Specular Component	SCI&SCE
Color Space	CIE LAB,XYZ,Yxy,LCh,CIE LUV,s-RGB,βxy,Munsell(C/2)
Color Difference Formula	ΔE*ab,ΔE*uv,ΔE*94,ΔE*cmc(2:1),ΔE*cmc(1:1),ΔE*00
Other Colorimetric Index	WI(ASTM E313, CIE/ISO,AATCC,Hunter), YI(ASTM D1925, ASTM 313), Staining Fastness, Color Fastness, Color Strength, Opacity, 8° Glossiness,
Observer Angle	2°/10°
Illuminant	D65,A,C,D50,F2(CWF),F7(DLF),F10(TPL5),F11(TL84),F12(TL83/U30)
Displayed Data	Spectrogram/Values, Samples Chromaticity Values, Color Difference Values/Graph, PASS/FAIL Result, Color Offset
Measurement Time	About 1.5s (Measure SCI & SCE about 3.2s)
Repeatability	Spectral reflectance: MAV/SCI, Standard deviation within 0.1% (400 nm to 700 nm: within 0.2%) Chromaticity value: MAV/SCI, within ΔE*ab 0.04 (When a white calibration plate is measured 30 times at 5 second intervals after white calibration)
Inter-instrument Error	MAV/SCI, Within ΔE*ab 0.2 (Average for 12 BCRA Series II color tiles)
Measurement Mode	Single Measurement, Average Measurement(2-99times)
Locating Method	Camera Locating, stabilizer cross position
Dimension	L*W*H=129X76X217mm
Weight	Approx 600g
Battery	3.7V,5000mAh Li-ion battery, 6000 measurements within 8 hours
Illuminant Life Span	5 years, more than 3 million times measurements
Displayed Data	3.5-inch TFT color LCD, Capacitive Touch Screen
Data Port	USB
Data Storage	Standard 1000 Pcs, Sample 20000 Pcs
Language	Simplified Chinese, English, traditional Chinese
Operating Environment	0~40℃, 0~85%RH (no condensing), Altitude < 2000m
Storage Environment	-20~50℃, 0~85%RH (no condensing)
Standard Accessory	Power Adapter, User Guide, PC Software(Download from office website), USB cable, White and Black Calibration Cavity, Protective Cover, Wrist strap, One aperture (8mm or 4mm)
Optional Accessory	Micro Printer, Powder Test Box
Notes	The specifications are subject to change without notice.

Colorimeter

SP-CLR8

Description

The SP-CLR8 is a portable spectrophotometer. It uses a built-in silicon photodiode array sensor and an imported white board, while the repeatability ΔE^*ab can be easily controlled within 0.04. Its powerful performance configuration and excellent inter-instrument error make color measurement more professional, while also ensuring the consistency of measurement data across multiple devices.

Features

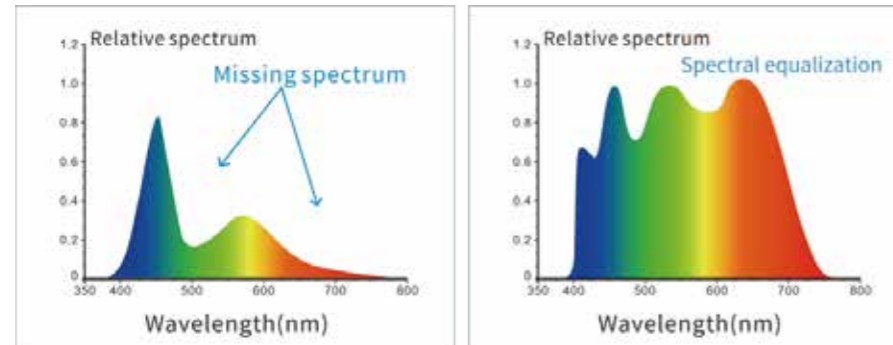

Adopts full-band balanced LED light source

The full-band balanced LED light source ensures sufficient spectral distribution in the visible light range, avoids the lack of spectrum of white LEDs in a specific band, and ensures the measurement speed of the instrument and the accuracy of the measurement results.



Features

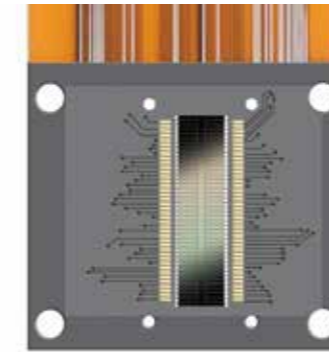

Silicon photodiode array (double 32 array) sensor

The dual-32 array sensor with larger area has strong light but not saturate, higher sensitivity of low light and wider spectral response range, which ensures the measurement speed, accuracy, stability and consistency of the instrument.



Place the base safely to ensure that the whiteboard is not dirty.



Professional whiteboard

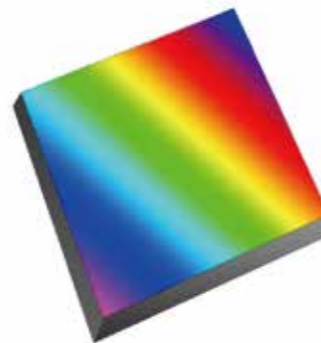

Grating Spectrophotometric technology

Using grating spectrophotometric technology, it has higher resolution and makes color measurement more accurate.



Fast charging

Special fast charging method, low-voltage reminder to charge or use of off-hours to charge, ensures the capacity and life of the battery (note: frequent repeated charging of the battery causes much harm).



Customize a single measuring aperture to accurately meet the needs of sample measurement

The SP-CLR8 spectrophotometer offers Ø8mm or Ø4mm platform apertures to meet your specific sample measurement requirements.



Excellent inter-instrument error and repeatability to ensure the consistency of measurement data across multiple devices.

Features



Novel and fashionable appearance design based on ergonomics

The position of the hand grip and the measurement button are carefully designed to meet different gripping habits. The smooth and fine surface is derived from the art of high-precision appearance processing.

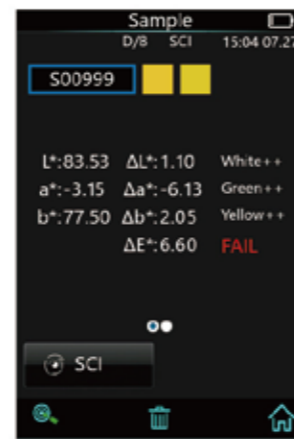

Diversified data display

The SP-CLR8 spectrophotometer can intuitively display reflectance (reflectance at three specific wavelengths specified by the user), sample chromaticity values, color difference values/graphs, pass/fail results, color simulation, color offset, and other data. This is convenient to view and also greatly improves the user's work efficiency.

Specification

Model	SP-CLR8
Optical Geometry	D/8 (diffuse illumination, 8° direction reception)
	SCI measurement
	Comply with standard CIE No.15, GB/T 3978, GB 2893, GB/T 18833, ISO7724-1, ASTM E1164, DIN5033 Teil7
Characteristics	Customized single measurement aperture for accurate color difference control in plastic and electronic, paint and ink, textile and garment printing and dyeing, printing, ceramics and other industries.
Integrating Sphere Size	Φ40mm
Light Source	Combined full-spectrum LED light source
Spectroscopic Method	Planar grating
Sensor	Silicon photodiode arrays (dual row 32 groups)

Specification

Model	SP-CLR8
Wavelength Range	400~700nm
Wavelength Interval	10nm
Semiband Bandwidth	10nm
Measurement Range	L: 0~120
	Reflectivity: the instrument can test the reflectivity at 3 specific wavelengths specified by the user (default 440nm, 550nm, 600nm)
Measurement Aperture	Single aperture: Φ8mm (Φ4mm optional)
Focusing Method	Fixed focus
Specular Component	SCI
Color Space	CIE LAB, XYZ, Yxy, LCh
Color Difference Formula	ΔE*ab, ΔE*00
Observer Angle	10°
Illuminant	D65, A, F2 (CWF)
Displayed Data	Reflectivity (at 3 specific wavelengths specified by the user), chromaticity value, color difference value/graph, pass/fail result, color simulation, color offset
Display Accuracy	0.01
Measurement Time	Approx. 1.5s
Repeatability	Chromaticity value: MAV/SCI, ΔE*ab within 0.04 (When a white calibration plate is measured 30 times at 5 second intervals after white calibration)
	Inter-instrument Error: MAV/SCI, within ΔE*ab 0.35 (Average for 12 BCRA Series II color tiles)
Measurement Method	Single measurement, average measurement (2~99 times)
Locating Method	Stabilizer locating
Battery Power	Lithium battery, 6000 times in 8 hours
Illuminant Life Span	5 years, more than 3 million times measurements
Display	TFT true color 3.5inch, capacitive touch screen
Data Port	USB, Bluetooth® 5.0
Data Storage	500 standard samples, 1,0000 samples
Language	English
Operating Temperature Range	0~40 °C, 0~85%RH (no condensation), altitude < 2000m
Storage Temperature Range	-20~50 °C, 0~85%RH (no condensation)
Standard Accessories	Power adapter, data cable, manual, black and white calibration box, protective cover, wrist strap, single aperture: Φ8mm (optional Φ4mm) platform aperture
Optional Accessories	USB micro printer, powder test box, Bluetooth micro printer, holder base
External Dimensions(L*W*H)	81*71*214mm
Weight	About 460g

Note: Technical specifications are for reference only and are subject to the actual product.

Colorimeter

SP-CLR9



Description

The SP-CLR8 is a portable spectrophotometer. It uses a built-in silicon photodiode array sensor and an imported white board, while the repeatability ΔE^*ab can be easily controlled within 0.04. Its powerful performance configuration and excellent inter-instrument error make color measurement more professional, while also ensuring the consistency of measurement data across multiple devices.

Features

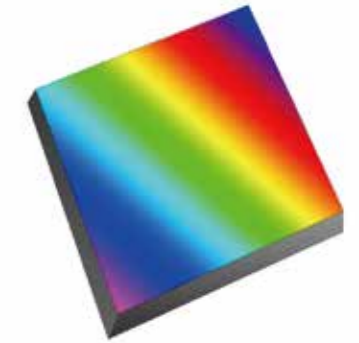
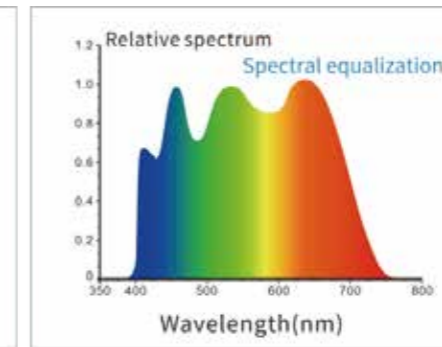
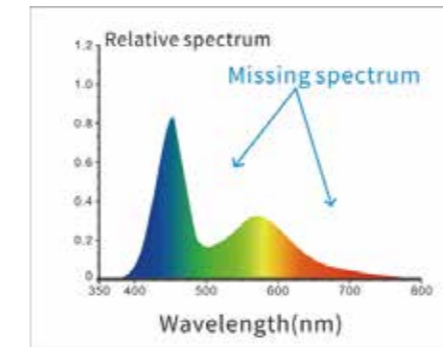

Adopts full-band balanced LED light source

The full-band balanced LED light source ensures sufficient spectral distribution in the visible light range, avoids the lack of spectrum of white LEDs in a specific band, and ensures the measurement speed of the instrument and the accuracy of the measurement results.

Grating Spectrophotometric technology

Using grating spectrophotometric technology, it has higher resolution and makes color measurement more accurate.

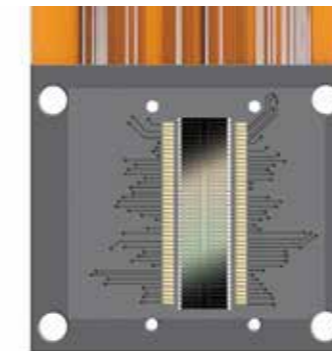

Silicon photodiode array (double 32 array) sensor

The dual-32 array sensor with larger area has strong light but not saturate, higher sensitivity of low light and wider spectral response range, which ensures the measurement speed, accuracy, stability and consistency of the instrument.



Place the base safely to ensure that the whiteboard is not dirty.



Professional whiteboard

Features



Fast charging

Special fast charging method, low-voltage reminder to charge or use of off-hours to charge, ensures the capacity and life of the battery (note: frequent repeated charging of the battery causes much harm).



Novel and fashionable appearance design based on ergonomics

The position of the hand grip and the measurement button are carefully designed to meet different gripping habits. The smooth and fine surface is derived from the art of high-precision appearance processing.



Equipped with 4/8mm dual measuring apertures to meet the measurement needs of different samples

The SP-CLR9 spectrophotometer offers Ø8mm and Ø4mm platform apertures to meet your specific sample measurement requirements.



Camera positioning for clear observation of the measured area

The SP-CLR9 spectrophotometer has a built-in camera for framing and positioning. Through the real-time framing of the camera, it can accurately determine whether the measured part of the object is the center of the target, thereby improving measurement efficiency and accuracy.

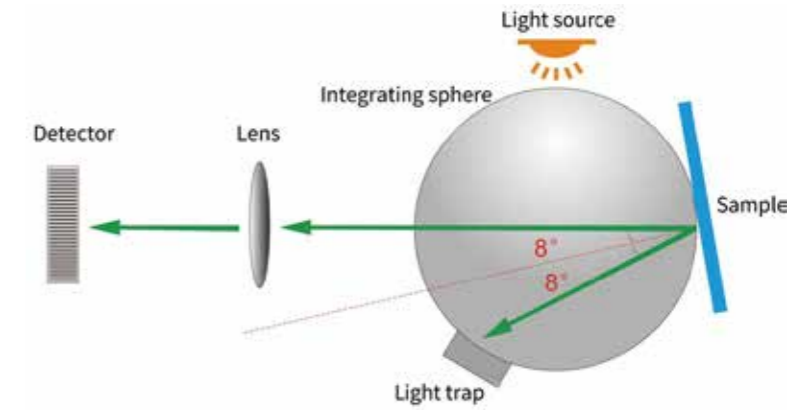

Adopts the internationally used D/8 SCI/SCE synthesis technology

The D/8 (SCI/SCE) measurement structure is adopted to reflect the color itself more objectively, and reduce the influence of the surface texture of the object on the test results.



Excellent inter-instrument error and repeatability to ensure the consistency of measurement data across multiple devices.



Multiple color spaces and multiple observation light sources

It provides CIE LAB, XYZ, Yxy, LCh, CIE LUV, s-RGB, βxy, DIN Lab9, DIN Lab99 Munsell (C/2) color spaces, as well as multiple observation light sources including D65, A, C, D50, D55, D75, F1, F2 (CWF), F3, F4, F5, F6, F7 (DLF), F8, F9, F10 (TPL5), F11 (TL84), and F12 (TL83/U30), which can meet the special measurement needs under different measurement conditions.

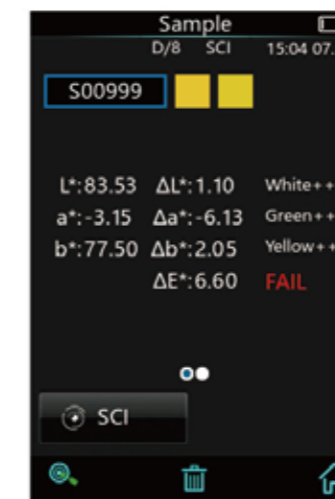

Diversified data display

The SP-CLR9 spectrophotometer can intuitively display reflectance graphs/values, sample chromaticity values, color difference values/graphs, pass/fail results, color simulation, color offset, and other data. This is convenient to view and also greatly improves the user's work efficiency.



Specification

Model	SP-CLR9
Optical Geometry	D/8 (diffuse illumination, 8° direction reception) SCI/SCE measurement Comply with standard CIE No.15, GB/T 3978, GB 2893, GB/T 18833, ISO7724-1, ASTM E1164, DIN5033 Teil7
Characteristics	Dual measurement aperture, wider adaptability; used for accurate color measurement and quality control in plastic and electronic, paint and ink, textile and garment printing and dyeing, printing, ceramics and other industries
Integrating Sphere Size	Φ40mm
Light Source	Combined full-spectrum LED light source, UV light source
Spectroscopic Method	Planar grating
Sensor	Silicon photodiode arrays (dual row 32 groups)
Wavelength Range	400~700nm
Wavelength Interval	10nm
Semiband Bandwidth	10nm
Measurement Range	L: 0~120 Reflectivity: 0~200%

Specification

Model	SP-CLR9
Measurement Aperture	Dual apertures: Φ8mm, Φ4mm
Focusing Method	Optical focus
Specular Component	SCI&SCE
Color Space	CIE LAB, XYZ, Yxy, LCh, CIE LUV, s-RGB, βxy, DIN Lab9, DIN Lab99 Munsell (C/2)
Color Difference Formula	ΔE*ab, ΔE*uv, ΔE*94, ΔE*cmc(2:1), ΔE*cmc(1:1), ΔE*00, DINΔE99
Other Colorimetric Indexs	WI (ASTM E313, CIE/ISO, AATCC, Hunter), YI (ASTM D1925, ASTM 313), Metamerism index Mt, staining fastness, color fastness, strength, opacity, color card search
Observer Angle	2°/10°
Illuminant	D65, A, C, D50, D55, D75, F1, F2 (CWF), F3, F4, F5, F6, F7 (DLF), F8, F9, F10 (TPL5), F11 (TL84), F12 (TL83/U30)
Displayed Data	Spectrogram/data, chromaticity value, color difference value/graph, pass/fail result, color simulation, color offset
Display Accuracy	0.01
Measurement Time	Approx. 1.5s (Measure SCI & SCE about 3.2s)
Repeatability	Chromaticity value: MAV/SCI, ΔE*ab within 0.03 (When a white calibration plate is measured 30 times at 5 second intervals after white calibration)
Inter-instrument Error	MAV/SCI, within ΔE*ab 0.3 (Average for 12 BCRA Series II color tiles)
Measurement Method	Single measurement, average measurement (2~99 times)
Locating Method	Camera locating, stabilizer locating
Battery Power	Lithium battery, 6000 times in 8 hours
Illuminant Life Span	5 years, more than 3 million times measurements
Display	TFT true color 3.5inch, capacitive touch screen
Data Port	USB, Bluetooth® 5.0
Data Storage	1000 standard samples, 30,000 samples (a piece of data can include SCI/SCE at the same time)
Language	English
Operating Temperature Range	0~40 C, 0~85%RH (no condensation), altitude < 2000m
Storage Temperature Range	-20~50 C, 0~85%RH (no condensation)
Standard Accessories	Power adapter, data cable, manual, black and white calibration box, protective cover, wrist strap, dual aperture: Ø8mm + Ø4mm platform aperture
Optional Accessories	USB micro printer, powder test box, Bluetooth micro printer, holder base
External Dimensions(L*W*H)	81*71*214mm
Weight	About 460g

Note: Technical specifications are for reference only and are subject to the actual product.