

Infitek

PCR CABINET



Infitek



Infitek



Infitek



Infitek



Infitek

Infitek

Infitek Co., Ltd.

TEL: +86-531-88982330

FAX: +86-531-88983691

Website: infitek.com

Email: info@infitek.com

Service: support@infitek.com

Address: Room 201, Building A, No.1 Qianwan 1st Road, Qianhai
Shenzhen-Hong Kong Cooperation Zone, Shenzhen (Settled in
Shenzhen Qianhai Business Secretary Co., Ltd.)

US Office

INFITEK INC.

522W RIVERSIDE AVE STE N,SPOKANE,WA 99201

EMAIL: INFO@INFITEK.COM

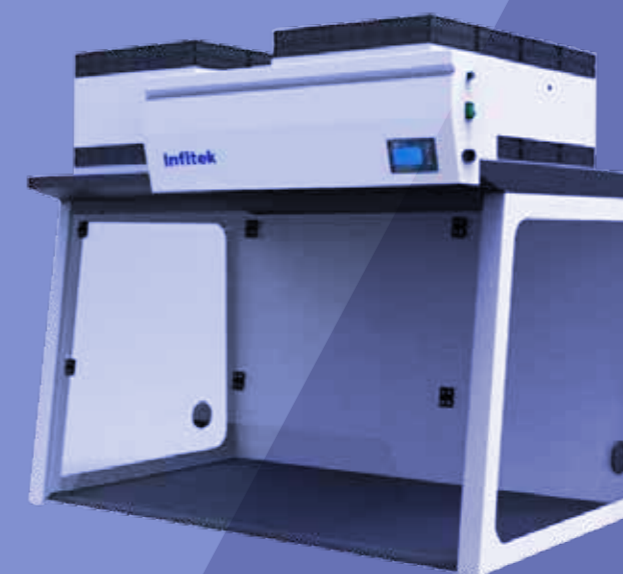

PCR Cabinet

LCB-V800II LCB-V1000II LCB-V1300II LCB-V1600II LCB-V1800II



Description

This product is mainly used to standardize the safe operation of chemicals and ensure the safety of experimental personnel and property. The product is equipped with a flexible modular filtration system and fan system, which can effectively filter different substances such as gas, powder and mixture of gas and powder. After filtration, clean air circulates indoors.



LCB-V1300II

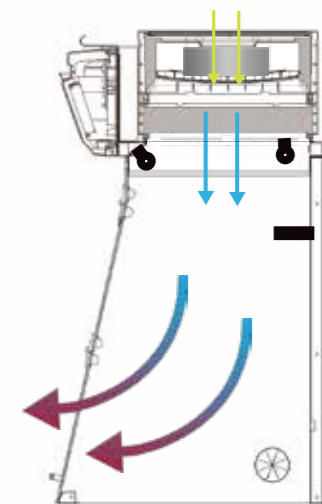

Filter type

- HF4TY: It has strong adsorption capacity for acidic gases and is compatible with the adsorption of organic gases. It is a universal filter.
- HF4AM: mainly for ammonia gases, followed by organic gases.
- HF4FM: mainly for formaldehyde, followed by organic gases.
- HF4HP: mainly for particle filtration, for particles larger than 0.3µm, the filtration efficiency is 99.995%.
- HF4YJ: mainly for organic gases, followed by acidic gases.

Features

- Metal part material: galvanized steel plate, coated with acid and alkali resistant epoxy polyester coating;
- The operating table is made of epoxy resin board;
- Features of cold fluorescent lighting: safe service life of more than 100,000 hours;
- LED display: 3.5-inch LED smart display, which displays the filter operating temperature, fan speed, instant surface wind speed, filter life countdown, and filter outlet TVOC concentration probe; The fan speed can be adjusted by the user according to usage conditions to ensure negative pressure in the cabinet.
- The TVOC concentration display accuracy at the filter outlet is 0.1PPM, and the alarm value can be set by yourself.
- The surface wind speed detection probe needs to be located on the front baffle of the fume hood, with a display accuracy of 0.1m/s.
- The filtration system has modular functions and can be equipped with corresponding filters for liquid or dust and mixing experiments, and has adsorption functions for 500 common chemical substances.



Specifications

Model	LCB-V800II	LCB-V1000II	LCB-V1300II	LCB-V1600II	LCB-V1800II
Internal Dimensions(W*D*H)mm	786*560*760	986*560*760	1286*690*760	1586*690*760	1786*690*760
External Dimensions(W*D*H)mm	800*620*890~1350	1000*620*890~1350	1300*790*920~1502	1600*790*930~1502	1800*790*940~1502
Filter Number	2	2	4	6	8
Air volume(m³/h)	240	240	480	720	960
Surface Wind Speed (m/s)	0.4~0.6	0.4~0.6	0.4~0.6	0.4~0.6	0.4~0.6
Noise(dBA)	≤50	≤50	≤54	≤57	≤57
Standard Accessories	Fluorescent lamp*1	Fluorescent lamp*1	Fluorescent lamp*2	Fluorescent lamp*3	Fluorescent lamp*4
	UV lamp*1	UV lamp*1	UV lamp*1	UV lamp*1	UV lamp*1
	Filter*2	Filter*2	Filter*4	Filter*6	Filter*8
Optional Accessories	Epoxy resin countertop*1	Epoxy resin countertop*1	Epoxy resin countertop*1	Epoxy resin countertop*1	Epoxy resin countertop*1
	Painted explosion-proof tempered glass countertop;Base Cabinet; Fluorescent lamp; Filter (HF4TY,HF4AM,HF4FM,HF4HP,HF4YJ)				